



**CHUCKS**



# Jacobs®



## taper mounted chucks

### Medium Duty Models

CHUCK MODEL	CODE NO.	CAP.	TAPERED MOUNT	USES KEY	LENGTH		DIAM.
					Closed	Open	
0	02002	0-5/32"	0 JT	K0	1 3/8	1 1/8	55/64
1A	02009	0-1/4	1 JT	K1	1 15/16	1 17/32	1 3/16
2A	02035	0-3/8	2 JT	K2	2 13/16	2 3/16	1 11/16
6A-2A	02065	0-1/2	2 JT	K3	3 7/16	2 5/8	1 15/16
6A-33	02067	0-1/2	33 JT	K3	3 7/16	2 5/8	1 15/16
633C*	02068	0-1/2	33 JT	K3C	3 21/32	2 27/32	1 15/16
633D**	02069	0-1/2	33 JT	K3C	3 21/32	2 27/32	1 15/16
33	02050	5/64-1/2	33 JT	K32	3 3/32	2 17/32	1 13/16
33F	02051	5/64-1/2	33 JT	K32	3 5/32	2 17/32	1 13/16
3326A	02052	5/64-1/2	5/8 Str.	K32	3 1/2	2 27/32	1 13/16
3333C*	02053	5/64-1/2	33 JT	K32C	3 7/32	2 9/16	1 13/16
33KD***	02054	5/64-1/2	33 JT	K32	3 7/16	2 25/32	1 25/32

With the exception of Models O and OB Chucks which have a minimum capacity of No. 80 drill, all medium and heavy duty plain bearing chucks and ball bearing chucks having a nominal capacity of 0 will hold a No. 70 drill.

### Heavy Duty Models

CHUCK MODEL	CODE NO.	CAP.	TAPERED MOUNT	USES KEY	LENGTH		DIAM.
					Closed	Open	
7	02015	0-1/4"	2 short JT	K7	2 7/32	1 25/32	1 19/64
7-1A	02016	0-1/4	1 JT	K7	2 7/32	1 21/32	1 19/64
30	02025	0-5/16	2 short JT	K30	2 5/16	1 29/32	1 27/64
32	02040	0-3/8	2 JT	K32	3 1/16	2 9/32	1 13/16
34	02075	0-1/2	6 JT	K3	3 17/32	2 11/16	2 1/16
3A	02086	1/8-5/8	3 JT	K3	3 13/16	2 7/8	2 5/16
36	02100	3/16-3/4	3 JT	K4	4 1/16	3 5/32	2 9/16
34KD***	02076	0-1/2	#6 JT	K3	3 11/16	2 15/16	2 1/16
34PD****	02077	0-1/2	#6 JT	K3	3 11/16	2 15/16	2 1/16
3KD***	02088	1/8-5/8	#3 JT	K3	4 1/16	3 1/8	2 5/16
3PD****	02089	1/8-5/8	#3 JT	K3	4 1/16	3 1/8	2 5/16
37KD***	02105	1/4-1 3/16	#3 JT	K4	4 11/32	3 13/32	2 9/16
37PD****	02106	1/4-1 3/16	#3 JT	K4	4 11/32	3 13/32	2 9/16

\*Equipped with a threaded locking collar which has a 1 1/16-20 thd.

\*\*Equipped with a threaded locking collar which has a 1 1/4-12 thd.

\*\*\*Equipped with a positive driving slot.

\*\*\*\*Equipped with a pin type positive drive

# plain bearing key type chucks

Manufacturers of power tools throughout the world have standardized on the Jacobs Plain Bearing Key Type Drill Chuck for original equipment. The reason is simple—no other drill chuck possesses the accuracy, the grip and the strength which can only be offered by the basic Jacobs internal construction. This fine chuck is offered for both *medium duty* or *heavy duty* portable, bench or floor type power tools in a wide range of capacities for either threaded or tapered mounting spindles. It is the world's most widely used drill chuck.

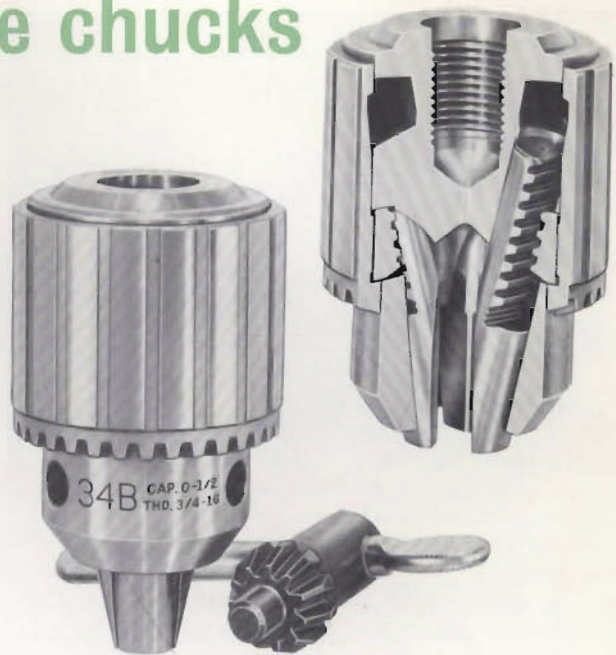

## thread mounted chucks

### Medium Duty Models

CHUCK MODEL	CODE NO.	CAP.	THREADED MOUNT	USES KEY	LENGTH		DIAM.
					Closed	Open	
0B 5/16-24	02003	0-5/32"	5/16-24	K0	1 1/2	1 3/16	5 5/64
1B 3/8-24	02005	0-3/16	3/8-24	K1	1 5/16	1 17/32	1 3/16
1BS	02008	0-3/16	short 3/8-24	K1	1 11/16	1 5/16	1 1/8
1B 3/8-24	02006	0-1/4	3/8-24	K1	1 5/16	1 17/32	1 3/16
1B 5/16-24	02007	0-1/4	5/16-24	K1	1 5/16	1 17/32	1 3/16
31B 3/8-24	02030	1/16-3/8	3/8-24	K30	2 13/32	1 15/16	1 27/64
31BA 3/8-24	02031	1/16-3/8	3/8-24 D/C	K30	2 13/32	1 15/16	1 27/64
31B 1/2-20	02032	1/16-3/8	1/2-20	K30	2 13/32	1 15/16	1 27/64
2B 3/8-24	02036	0-3/8	3/8-24	K2	2 3/16	2 3/16	1 11/16
6B 1/2-20	02071	0-1/2	1/2-20	K3	3 1/2	2 23/32	1 15/16
33B 3/8-24	02056	5/64-1/2	3/8-24	K32	3 3/32	2 7/16	1 13/16
33B 1/2-20	02057	5/64-1/2	1/2-20	K32	3 3/32	2 7/16	1 13/16
33BA 1/2-20	02059	5/64-1/2	1/2-20 D/C	K32	3 3/32	2 7/16	1 13/16
33BA 5/8-16	02060	5/64-1/2	5/8-16 D/C	K32	3 3/32	2 7/16	1 13/16

### Heavy Duty Models

CHUCK MODEL	CODE NO.	CAP.	THREADED MOUNT	USES KEY	LENGTH		DIAM.
					Closed	Open	
7B 3/8-24	02017	0-1/4"	3/8-24	K7	2 7/32	1 23/32	1 19/64
7B 1/2-20	02018	0-1/4	1/2-20	K7	2 7/32	1 3/4	1 19/64
30B 3/8-24	02027	0-5/16	3/8-24	K30	2 13/32	1 29/32	1 27/64
30B 1/2-20	02028	0-5/16	1/2-20	K30	2 13/32	1 29/32	1 27/64
32B 1/2-20	02041	0-3/8	1/2-20	K32	3 1/16	2 5/16	1 13/16
32B 5/8-16	02042	0-3/8	5/8-16	K32	3 1/16	2 5/16	1 13/16
32B 45/64-16	02043	0-3/8	45/64-16	K32	3	2 5/16	1 13/16
34B 5/8-16	02078	0-1/2	5/8-16	K3	3 17/32	2 3/4	2 1/16
34B 45/64-16	02079	0-1/2	45/64-16	K3	3 17/32	2 3/4	2 1/16
34B 3/4-16	02080	0-1/2	3/4-16	K3	3 17/32	2 3/4	2 1/16
3B 5/8-16	02091	1/8-5/8	5/8-16	K3	3 13/16	2 7/8	2 5/16
36B 5/8-16	02101	3/16-3/4	5/8-16	K4	4 1/8	3 7/32	2 9/16
36B 3/4-16	02102	3/16-3/4	3/4-16	K4	4 1/8	3 7/32	2 9/16

All Jacobs threaded back, plain bearing chucks can be identified by the letter "B" in the model number. These models can be readily removed from their threaded spindles by following the instructions found on page 15.

Information covering the repair or reconditioning of Jacobs drill chucks is also shown on page 15.

D/C—These models are drilled and countersunk for retaining screws.



## plain bearing key type chucks

The Jacobs plain bearing type chuck can easily be repaired by purchasing the necessary parts from your nearby Jacobs distributor. The careful controls exercised in the manufacture of Jacobs chucks guarantee the complete interchangeability of parts. Instructions for repairing Jacobs chucks are shown on page 15. Your distributor will also be happy to return your worn chucks to our factory for reconditioning. This service is described on page 15.



CHUCK MODEL	KEY	JAWS & NUT UNIT	SLEEVE
0, 0B	K0	U0	S0
1A, 1B	K1	U1	S1
2A, 2B	K2	U2	S2
3 (17/32 cap.)	K3	U3R	S3
3A, 3AE, 3B, 3KD, 3PD	K3	U3	S3
6A-33, 6AE, 6A-2A, 6B	K3	U6	S6
633C, 633D	K3C	U6	S6
7, 7-1A, 7B	K7	U7	S7
30, 30-1A, 30B, 31B	K30	U30	S30
32, 32B	K32	U32	S32
33, 33B, 3326, 33F, 33KD	K32	U33	S32
3333C	K32C	U33	S32
34, 34B, 34KD, 34PD	K3	U34	S34
36, 36E, 36B	K4	U36	S36
37, 37KD, 37PD	K4	U37	S36

Sleeves, Jaws and Nuts are always interchangeable between tapered back and threaded back models. For example 1A and 1B.

Code numbers for chuck parts are shown on all price sheets.

### Jacobs Self-Ejecting Keys

The spring-loaded ejector is designed to prevent the geared key from remaining in the drill chuck after tightening.



KEY NO.	CODE NO.	USED ON CHUCK MODELS
SK-3C	03563	6A, 6AE, 6B, 633C, 633D, 34, 34B, 34KD, 34PD, 3, 3A, 3AE, 3B, 3KD, 3PD, 14N, 55B, 56B, 58B, 75A
SK-32C	03568	32, 32B, 33, 33B, 33BA, 3326, 33KD, 33F, 3333C, 11N
SK-K	03570	MC4, MC8, U8, H8, DC8

# Jacobs®

## ball bearing super chucks — key type extra-heavy duty

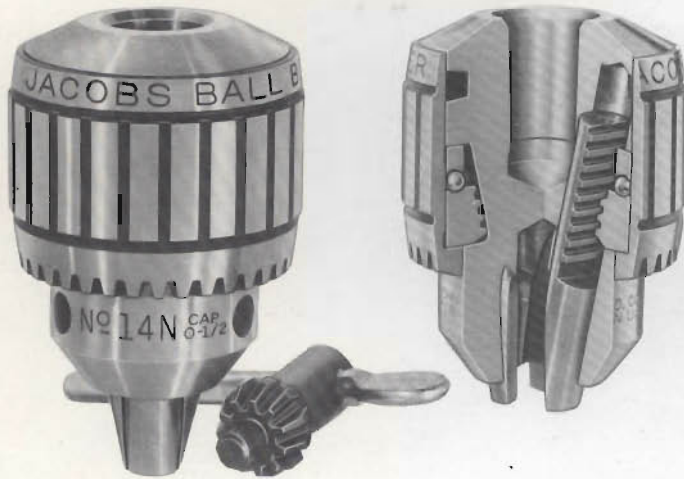

The Jacobs Ball Bearing Super Chuck is designed especially for EXTRA HEAVY DUTY drilling applications on production drilling machines, radials, jig borers, millers and lathes. It is also the world's MOST ACCURATE key type chuck which further qualifies it for those jobs where close tolerance drilling is desirable. The ball thrust bearing reduces friction in the chuck's closing mechanism, thus permitting the operator to apply greater tightening on the twist drill shank.

CHUCK MODEL	CODE NO.	CAPACITY	TAPERED MOUNT	USES KEY	WEIGHT Lbs. Ozs.	LENGTH		DIAM.
						Closed	Open	
8½N	03001	0-¼"	2 short JT	K30	0-9	2 <sup>13</sup> / <sub>32</sub>	1 <sup>7</sup> / <sub>8</sub>	1 <sup>9</sup> / <sub>16</sub>
11N	03002	0- <sup>3</sup> / <sub>8</sub>	2 JT	K32	1-2	2 <sup>7</sup> / <sub>8</sub>	2 <sup>1</sup> / <sub>4</sub>	1 <sup>5</sup> / <sub>16</sub>
14N	03003	0-½	3 JT	K3	2-6	3 <sup>7</sup> / <sub>8</sub>	2 <sup>31</sup> / <sub>32</sub>	2 <sup>7</sup> / <sub>16</sub>
16N	03004	½- <sup>5</sup> / <sub>8</sub>	3 JT	K4	2-15	4 <sup>5</sup> / <sub>16</sub>	3 <sup>1</sup> / <sub>4</sub>	2 <sup>5</sup> / <sub>8</sub>
18N	03005	½-¾	4 JT	K4	4-4	5 <sup>1</sup> / <sub>8</sub>	3 <sup>31</sup> / <sub>32</sub>	3 <sup>1</sup> / <sub>64</sub>
20N	03006	<sup>3</sup> / <sub>8</sub> -1	5 JT	K5	7-0	5 <sup>1</sup> / <sub>2</sub>	4 <sup>1</sup> / <sub>4</sub>	3 <sup>21</sup> / <sub>32</sub>

## ball bearing super chuck parts

CHUCK MODEL	KEY	JAWS & NUT UNIT	SLEEVE	THRUST RACE & BALLS
8½N	K30	U8½N	S8½N	T8½
11N	K32	U11N	S11N	T11
14N	K3	U14N	S14N	T14
16N	K4	U16N	S16N	T16
18N	K4	U18N	S18N	T18
20N	K5	U20N	S20N	T20

Code numbers for chuck parts are shown on all price sheets.



# lathe headstock and armature chucks

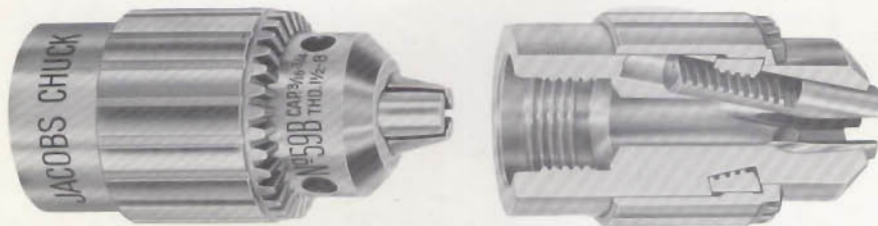

HEADSTOCK  
CHUCKS

CHUCK MODEL	CODE NO.	CAP.	TAPERED or THREADED MOUNT	USES KEY	WEIGHT Lbs. Ozs.	LENGTH		DIAM.
						Closed	Open	
55B 1-8	03050	*0-17/32"	1-8	K3	2-4	4	3 1/16	2 5/16
56B 1-10	03051	*0-17/32	1-10	K3	2-5	4	3 1/16	2 5/16
58B 1 1/2-8	03052	1/8-5/8	1 1/2-8	K3	2-7	4 21/32	3 3/4	2 5/16
59B 1 1/2-8	03053	3/16-3/4	1 1/2-8	K4	3-10	5 1/32	4 1/8	2 1/16

\*Models 55B and 56B can be provided with optional capacity of 1/8-5/8"

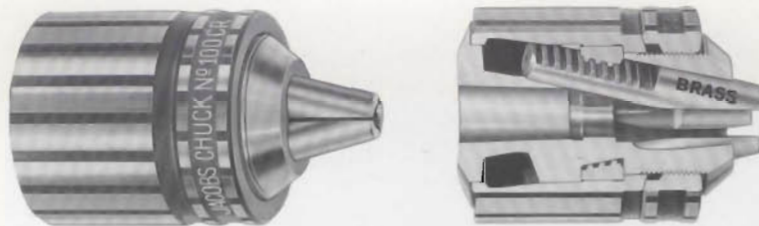

ARMATURE  
DRIVING CHUCK  
CENTER REST  
CHUCK

CHUCK MODEL	CODE NO.	CAP.	TAPERED or THREADED MOUNT	USES KEY	WEIGHT Lbs. Ozs.	LENGTH		DIAM.
						Closed	Open	
75A	03054	1/4-3/4	3 JT	K3	1-15	3 5/8	2 7/8	2 5/16
100CR	03055	1/4-3/4	3 JT	Keyless	2-3	3 7/8	2 7/8	2 5/16

## headstock and center rest chuck parts

CHUCK MODEL	KEY	JAWS & NUT UNIT	SLEEVE
55B 1-8	K3	U3R	S3
56B 1-10	K3	U3R	S3
58B 1 1/2-8	K3	U3	S3
59B 1 1/2-8	K4	U36	S36
75A	K3	U75	S3
100CR	Keyless	U100	S100

Jacobs Lathe Headstock Chucks are designed to thread directly onto lathe spindles. Their capacity range, extreme accuracy, and ease of operation allows them to replace costly collet equipment. Their hollow construction makes possible the chucking of long pieces extending into the lathe spindle.

The Jacobs Armature Chuck Model 100CR, when mounted by means of a tapered arbor in the tailstock of a lathe, replaces a center. It provides an accurate support for turning round work when a center cannot be used. The stationary brass jaws provide an excellent bearing surface. The jaws can be adjusted to the diameter of the work to be supported and then locked.



Jacobs Commutator Kit  
Code No. 03056

A complete unit designed specifically for holding armature shafts rigidly and accurately during reconditioning. This kit contains a No. 75A Armature Driving Chuck and a No. 100 Center Rest Chuck both mounted on No. 2 Morse Taper Arbors which replace lathe centers. The Jacobs Commutator Kit will pay for itself on the first few armatures serviced. (No. 1 Morse Taper Arbors Optional).

# Jacobs®

## tap chucks with Rubber-Flex® collets

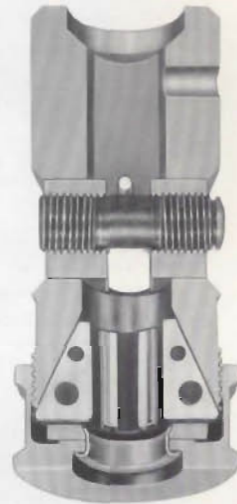
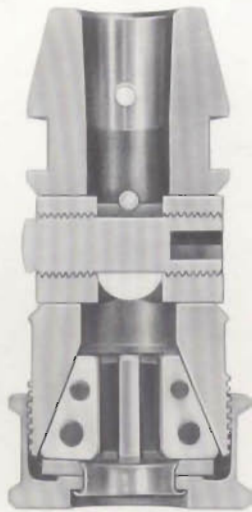

These tap chucks are designed for tapping machines and portable tappers and are offered in a variety of mounts with these essential features:

**Small Diameter**—Means that the weight is close to the center-line, reducing torsional inertia.

**Capacity**—Each model with one interchangeable RUBBER-FLEX collet will hold an unusually wide range of tap sizes.

**Positive Drive**—Provided by floating back jaws which always locate on the square of the tap shank.

**Simplified Tap Changing**—One quarter turn of the screw and the nut disengages back jaws. The tap shank sighting hole presents full view of tap square during change over.

**Accuracy**—The RUBBER-FLEX collet centralizes the tap as it seats in its precision-ground locating cone.

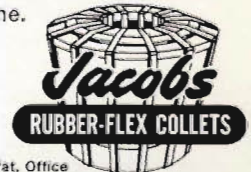

Reg. U.S. Pat. Office

CHUCK MODEL	CODE NO.	TAP CAPACITY	COLLET NO.	MOUNT	OVERALL LENGTH		LARGEST DIAM.	NUT WRENCH FLAT	BODY WRENCH FLAT	HEX KEY SIZE	ROUND SHANK CAPACITY		SQUARE OR FLAT CAPACITY	
					MAX. CAP.	MIN. CAP.					MIN.	MAX.	MIN.	MAX.
400-01	03755	#0-#10	J-400	1 JT	1 <sup>15</sup> / <sub>16</sub>	1 <sup>27</sup> / <sub>32</sub>	2 <sup>7</sup> / <sub>32</sub>	3/4	1/2	3/32	.141	.194	.090	.152
420-01	03756	#10-5/16	J-420	1 JT	2 1/2	2 <sup>5</sup> / <sub>16</sub>	1 <sup>3</sup> / <sub>32</sub>	3 <sup>1</sup> / <sub>32</sub>	1 <sup>1</sup> / <sub>16</sub>	1/8	.194	.318	.090	.238
420-02	03757	#10-5/16	J-420	2 short JT	2 1/2	2 <sup>5</sup> / <sub>16</sub>	1 <sup>3</sup> / <sub>32</sub>	3 <sup>1</sup> / <sub>32</sub>	1 <sup>1</sup> / <sub>16</sub>	1/8	.194	.318	.090	.238
421-01	03758	#0-1/4	J-421	1 JT	2 1/2	2 <sup>5</sup> / <sub>16</sub>	1 <sup>3</sup> / <sub>32</sub>	3 <sup>1</sup> / <sub>32</sub>	1 <sup>1</sup> / <sub>16</sub>	1/8	.141	.255	.090	.238
421-02	03759	#0-1/4	J-421	2 short JT	2 1/2	2 <sup>5</sup> / <sub>16</sub>	1 <sup>3</sup> / <sub>32</sub>	3 <sup>1</sup> / <sub>32</sub>	1 <sup>1</sup> / <sub>16</sub>	1/8	.141	.255	.090	.238
421-J8	03760	#0-1/4	J-421	3/8" Sq. Hole	2 <sup>5</sup> / <sub>16</sub>	2 1/8	1 <sup>3</sup> / <sub>32</sub>	3 <sup>1</sup> / <sub>32</sub>	none	1/8	.141	.255	.090	.238
440-02	03765	5/16-5/8	J-440	2 JT	3 <sup>3</sup> / <sub>32</sub>	2 7/8	1 <sup>15</sup> / <sub>32</sub>	1 <sup>5</sup> / <sub>16</sub>	3 <sup>1</sup> / <sub>32</sub>	5/32	.318	.500	.118	.360
440-06	03766	5/16-5/8	J-440	6 JT	3 <sup>3</sup> / <sub>32</sub>	2 7/8	1 <sup>15</sup> / <sub>32</sub>	1 <sup>5</sup> / <sub>16</sub>	3 <sup>1</sup> / <sub>32</sub>	5/32	.318	.500	.118	.360
440-J10	03767	5/16-5/8	J-440	5/8" Sq. Hole	3 <sup>3</sup> / <sub>32</sub>	2 7/8	1 <sup>15</sup> / <sub>32</sub>	1 <sup>5</sup> / <sub>16</sub>	none	5/32	.318	.500	.118	.360
441-02	03768	#10-1/2	J-441	2 JT	3 <sup>3</sup> / <sub>32</sub>	2 7/8	1 <sup>15</sup> / <sub>32</sub>	1 <sup>5</sup> / <sub>16</sub>	3 <sup>1</sup> / <sub>32</sub>	5/32	.194	.381	.118	.360
441-06	03769	#10-1/2	J-441	6 JT	3 <sup>3</sup> / <sub>32</sub>	2 7/8	1 <sup>15</sup> / <sub>32</sub>	1 <sup>5</sup> / <sub>16</sub>	3 <sup>1</sup> / <sub>32</sub>	5/32	.194	.381	.118	.360
441-J9	03770	#10-1/2	J-441	1/2" Sq. Hole	3 1/8	2 7/8	1 <sup>15</sup> / <sub>32</sub>	1 <sup>5</sup> / <sub>16</sub>	none	5/32	.194	.381	.118	.360

The J-420 Collet is interchangeable with the J-421. Thus a J-421 Collet mounted in a 420-01 Chuck changes its range to hold #0-1/4" Taps.

The same interchangeability is possible between the J-440 Collet and the J-441.

Also available is the J-422 Collet (interchangeable with the J-420 and J-421) which has a tap capacity of 1/4"-1/2".

The price of the chuck includes the body wrench, the nut wrench and the hex key.

# Jacobs

## tap chuck Rubber-Flex<sup>®</sup> collets and parts

The Jacobs Rubber-Flex<sup>®</sup> Collet, "the collet with a range," is entirely different in design and operation from any collet now in use. Its features include the following distinct advantages:

1. Ability of each collet to handle a wide range of shank sizes.
2. Extreme simplicity of design—one piece construction—with all working surfaces precision ground after molding.
3. Tremendous gripping power provided by a high degree of parallelism maintained on all jaw surfaces.
4. All jaws made from hardened nickel molybdenum alloy steel to provide greater resistance to wear.

The body of the collet is made of a synthetic rubber compound which is permanently bonded to and passes through holes in the hardened steel jaws. Past performance has proved that this type of collet has tremendous life brought about by its resistance to set, and to deterioration normally caused by heat, coolants, and cutting compounds. The hardened and ground collet jaw segments located in a ground conical bore in the chuck body assure an unusually concentric relationship between the tap and the chuck. Tap runout is thus reduced to a minimum.

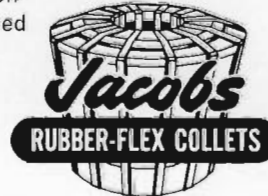
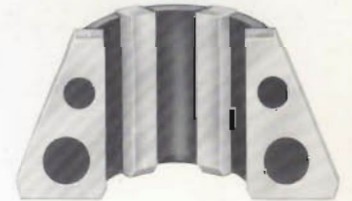

Reg. U.S. Pat. Office

CHUCK MODEL	BODY	NUT	COLLET	BACK JAWS	NUT WRENCH	BODY WRENCH	HEX KEY
400-01	B40001	N410	J400	U400	K400N	K400B	K59
420-01	B42001	N421	J420	U420	K420N	K420B	K60
420-02	B42002	N421	J420	U420	K420N	K420B	K60
421-01	B42101	N421	J421	U420	K420N	K420B	K60
421-02	B42102	N421	J421	U420	K420N	K420B	K60
421-J8	B421J8	N421	J421	U420	K420N	none	K60
440-02	B44002	N441	J440	U440	K440N	K420N	K61
440-06	B44006	N441	J440	U440	K440N	K420N	K61
440-J10	B440J10	N441	J440	U440	K440N	none	K61
441-02	B44102	N441	J441	U440	K440N	K420N	K61
441-06	B44106	N441	J441	U440	K440N	K420N	K61
441-J9	B441J9	N441	J441	U440	K440N	none	K61

Code numbers for chuck parts are shown on all price sheets.



# Jacobs

## impact keyless chuck with Rubber-Flex® collet

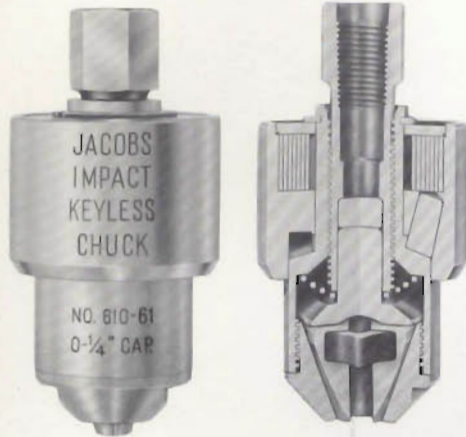

The Jacobs Impact Keyless Chuck is a new type of keyless chuck operating on an entirely new principle which employs the use of a "Hammer Blow" to grip or release the twist drill. Both large and small drills are held true and tight by the tremendous gripping power of the famous Jacobs Rubber-Flex Collet, yet the impact device provides a rapid and simple release of the twist drill. The principal application for this chuck will be on work where frequent tool changes are necessary, or where drilling torques are high.

The complete chuck consists of two components, the chuck proper and its mounting adapter. The adapter is provided with a 3/8-24 internal mounting thread and can be mounted on 1/4" electric and pneumatic drills with a standard 3/8-24 spindle.



Reg. U.S. Pat. Office

CHUCK MODEL	CODE NO.	CAPACITY	MOUNT	WEIGHT Lbs. Ozs.	LENGTH	DIAMETER
610-61	05100	0-1/4"	3/8-24 thd.	0-10	2 7/8	1 1/2

## impact keyless chuck parts

CHUCK MODEL	ADAPTER	SNAP RING	COVER PLATE	CLOCK SPRING	IMPACT SLEEVE	BODY	COIL SPRING THRUST PLUG	COLLET	NOSE
610-61	AD610-61	RR610	CP610	CS610	S610	B610	Spring TS610 Plug T610	J610	N610

## model 100-61 die grinder chuck and series 100 Rubber-Flex collets

The Model 100-61 Chuck with its Series 100 Rubber-Flex® Collets is a compact collet chuck with 3/4" diameter and 1 1/8" length designed for holding mounted points and rotary files on pneumatic and electric die grinders. The series 100 Collets and the N-100 Nut are also furnished separately for tools having a collet seating cone built into the spindle.



MODEL NO.		CODE NO.		MOUNT	
100-61 chuck (less collets and wrenches)		05005		3/8-24 thd.	
COLLET NO.	CODE NO.	MINIMUM CAP.	MAXIMUM CAP.	JAWS PER COLLET	
J-112	05012	.094	.146	5	
J-113	05013	.146	.198	6	
J-114	05014	.198	.250	8	



## albrecht keyless chuck

The Albrecht Chuck is "The World's Most Accurate Keyless Drill Chuck" and is widely used today on high accuracy drill presses, jig borers, milling machines and production drilling equipment. An ideal closure for those who desire a keyless type drill chuck and for those seeking the ultimate in drill chuck accuracy.

Model 15-JO keyless drill chuck is especially designed for holding small diameter twist drills and has a micrometer graduation on its sleeve to facilitate the changing of the smallest drills. This model has a minimum capacity of .008" and a max. capacity of 1/16".

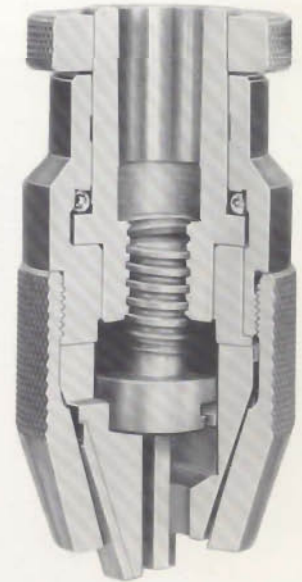
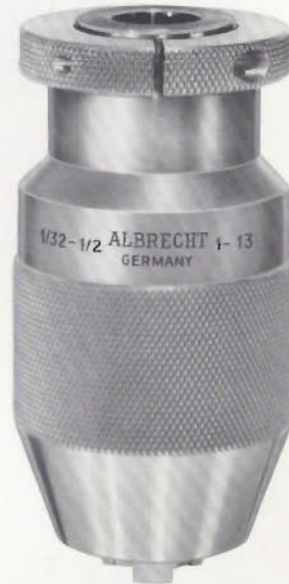

## taper mounted albrecht chucks

CHUCK MODEL NO.	CODE NO.	CHUCK CAPACITY	MOUNT	DIAMETER	LENGTH		WEIGHT Lbs. -Ozs.
					JAWS Open	JAWS Closed	
15 J0	05505	0-1/16"	0 JT	3/4"	1 15/32"	1 15/32"	0-1 3/4
30 J0	05506	0-1/8"	0 JT	15/16"	1 47/64"	1 7/8"	0-3 1/2
30 J1	05507	0-1/8"	1 JT	15/16"	1 47/64"	1 7/8"	0-3 1/2
50 J1	05510	0-3/16"	1 JT	1 3/16"	2 7/32"	2 7/16"	0-7
65 J1	05515	0-1/4"	1 JT	1 11/32"	2 7/16"	2 11/16"	0-10
80 J2	05525	0-5/16"	2 Short JT	1 1/2"	2 23/32"	3 1/16"	0-14 3/4
100 J33	05530	0-3/8"	33 JT	1 11/16"	3 5/32"	3 19/32"	1-5 1/2
100 J2	05531	0-3/8"	2 JT	1 11/16"	3 5/32"	3 19/32"	1-5 1/2
130 J33	05540	1/32-1/2"	33 JT	1 31/32"	3 9/16"	4 1/16"	2-1 1/4
130 J2	05541	1/32-1/2"	2 JT	1 31/32"	3 9/16"	4 1/16"	2-1 1/4
130 J6	05542	1/32-1/2"	6 JT	1 31/32"	3 9/16"	4 1/16"	2-1 1/4
160 J6	05550	1/8-5/8"	6 JT	2 7/32"	3 3/4"	4 9/32"	2-12

Minimum capacity of Model 15 J0 is approximately .008—all other models having a listed minimum capacity of "0" will hold a #80 Drill.

# thread mounted albrecht chucks

CHUCK MODEL NO.	CODE NO.	CHUCK CAPACITY	MOUNT	DIAMETER	LENGTH		WEIGHT Lbs. - Ozs.
					JAWS Open	JAWS Closed	
30 5/16-24	05508	0-1/8"	5/16-24	15/16"	1 7/64"	1 7/8"	0-3 1/2
50 5/16-24	05511	0-3/16"	5/16-24	1 3/16"	2 7/32"	2 7/16"	0-7
65 5/16-24	05517	0-1/4"	5/16-24	1 11/32"	2 7/16"	2 1 1/16"	0-10 1/4
65 3/8-24	05518	0-1/4"	3/8-24	1 11/32"	2 7/16"	2 1 1/16"	0-10 1/4
65 1/2-20	05519	0-1/4"	1/2-20	1 11/32"	2 7/16"	2 1 1/16"	0-10 1/4
80 3/8-24	05526	0-5/16"	3/8-24	1 1/2"	2 23/32"	3 1/16"	0-14 3/4
80 1/2-20	05527	0-5/16"	1/2-20	1 1/2"	2 23/32"	3 1/16"	0-14 3/4
100 1/2-20	05532	0-3/8"	1/2-20	1 11/16"	3 5/32"	3 19/32"	1-5 1/2
100 5/8-16	05533	0-3/8"	5/8-16	1 11/16"	3 5/32"	3 19/32"	1-5 1/2
130 1/2-20	05543	1/32-1/2"	1/2-20	1 31/32"	3 9/16"	4 1/16"	2-1 1/4
130 5/8-16	05544	1/32-1/2"	5/8-16	1 31/32"	3 9/16"	4 1/16"	2-1 1/4
130 3/4-16	05545	1/32-1/2"	3/4-16	1 31/32"	3 9/16"	4 1/16"	2-1 1/4
160 3/4-16	05551	1/8-5/8"	3/4-16	2 7/32"	3 3/4"	4 9/32"	2-12

# albrecht chuck parts

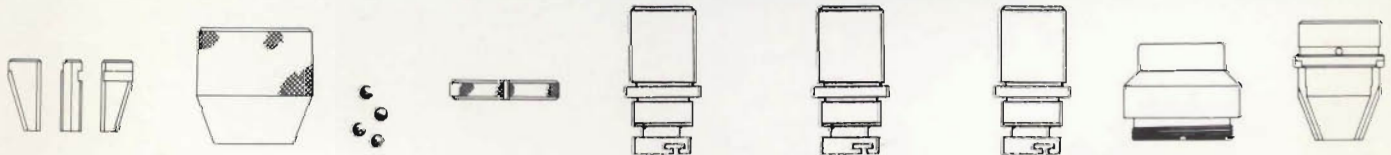

JAWS (Set of 3)	HOODS	BALLS (Set)	COLLARS	BODY ASSY.*	BODY ASSY.*	BODY ASSY.*	SHELLS	JAW GUIDES
U-15J	H-15J	BB-15J	C-30J	B-30J0	B-65 1/2-20	B-130J33	S-30J	G-30J
U-30J	H-30J	BB-30J	C-50J	B-30J1	B-80J2	B-130J2	S-50J	G-50J
U-50J	H-50J	BB-50J	C-65J	B-30 5/16-24	B-80 3/8-24	B-130J6	S-65J	G-65J
U-65J	H-65J	BB-65J	C-80J	B-50J1	B-80 1/2-20	B-130 1/2-20	S-80J	G-80J
U-80J	H-80J	BB-80J	C-100J	B-50 5/16-24	B-100J33	B-130 5/8-16	S-100J	G-100J
U-100J	H-100J	BB-100J	C-130J	B-65J1	B-100J2	B-130 3/4-16	S-130J	G-130J
U-130J	H-130J	BB-130J	C-160J	B-65 5/16-24	B-100 1/2-20	B-160J6	S-160J	G-160J
U-160J	H-160J	BB-160J		B-65 1/8-24	B-100 3/8-16	B-160 3/4-16		

\*Include Jaw Carrier Spindles

Code numbers for Albrecht chuck parts are shown on all price sheets.

## TAPER SHANK ARBORS

SHANK TAPER	JACOBS TAPERS								
	0	1	2*	3	4	5	6	E	33
#0 Morse	A0000	**	**	A0003	**	**	**	**	A0033
#1 Morse	A0100	A0101	A0102	A0103	A0104	**	A0106	**	A0133
#2 Morse	A0200	A0201	A0202	A0203	A0204	A0205	A0206	A0221	A0233
#3 Morse	**	A0301	A0302	A0303	A0304	A0305	A0306	**	A0333
#4 Morse	**	**	A0402	A0403	A0404	A0405	A0406	**	A0433
#5 Morse	**	**	A0502	A0503	A0504	A0505	A0506	**	**
#7 Brown & Sharpe**	**	**	A0702	A0703	**	**	A0706	**	**
#9 Brown & Sharpe**	**	**	**	A0903	A0904	**	A0906	**	**
#10 Brown & Sharpe**	**	**	**	A1003	A1004	**	**	**	**
R-8 (Bridgeport)	**	**	A0802	A0803	A0804	**	A0806	**	A0833



## STRAIGHT SHANK ARBORS

SHANK DIAMETER AND LENGTH	JACOBS TAPERS								
	0	1	2*	3	4	5	6	E	33
1/2" x 2 1/2"	A4000	A4001	A4002	A4003	A4004	**	A4006	**	A4033
5/8" x 2 1/2"	**	A4101	A4102	A4103	A4104	**	A4106	**	A4133
3/4" x 3"	**	**	A4202	A4203	A4204	**	A4206	**	A4233
1" x 3"	**	**	A4302	A4303	A4304	**	A4306	**	A4333
1 1/2" x 4"	**	**	**	A4503	A4504	**	**	**	**
1 3/4" x 4"	**	**	**	A4603	A4604	**	**	**	**



## MOTOR SHAFT ADAPTERS

MOTOR SHAFT SIZE	JACOBS TAPERS								
	0	1	2	3	4	5	6	E	33
1/2" Dia.	**	**	AD2502	AD2503	**	**	AD2506	**	AD2533

## THREADED ARBORS

SHANK TAPER	THREAD	PART NO.
#2 Morse	3/8-24	A0261
#2 Morse	1/2-20	A0264
#2 Morse	5/8-16	A0268

\*Arbors with the No. 2 Jacobs Taper will be supplied for use with chucks having a #2 short Jacobs Taper Mounting hole.

\*\*These arbors are special. Prices and delivery will be quoted upon application.

Code Numbers for Jacobs arbors and adaptors are shown on all price sheets.

Always specify Jacobs arbors to secure the finest performance from Jacobs drill and tap chucks. They are precision ground to our master gages and guarantee the finest possible accuracy and fit. Jacobs arbors feature a hardened tang which prevents damage by the drift in the knock-out process.

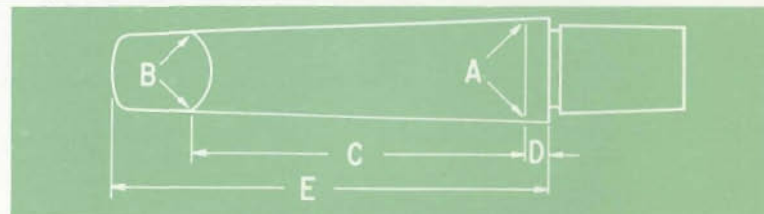

	NO.	A	B	C	D	E
MORSE TAPER	0	.3561	.252	2	1/8	2 11/32
	1	.475	.369	2 1/8	1/8	2 9/16
	2	.700	.572	2 9/16	3/16	3 1/8
	3	.938	.778	3 3/16	3/16	3 3/8
	4	1.231	1.020	4 1/16	1/4	4 7/8
BROWN & SHARPE TAPER	5	1.748	1.475	5 3/16	1/4	6 1/8
	7	.725	.600	3	3/32	3 5/8
	9	1.067	.900	4	1/8	4 3/4
	10	1.289	1.0446	5 11/16	1/8	6 17/32

# taper dimensions and arbor interchangeability

JACOBS TAPER	LARGE DIAMETER	SMALL DIAMETER	LENGTH OF TAPER	TAPER PER FOOT	USED IN CHUCK MODELS
0	.25000	.22844	.43750	.59145	0
1	.38400	.33341	.65625	.92508	1A, 7-1A, 30-1A, 250-1A, 400-01, 420-01, 421-01, 650-01
2	.55900	.48764	.87500	.97861	2A, 6A-2A, 11N, 32, 375, 440-02, 441-02
2 short	.54880	.48764	.75000	.97861	7, 8½N, 30, 250, 312, 420-02, 421-02, 650-S2, 660-S2
3	.81100	.74610	1.21875	.63898	3, 3A, 14N, 16N, 36, 75A, 100CR
4	1.12400	1.03720	1.65625	.62886	18N
5	1.41300	1.31611	1.87500	.62010	20N
6	.67600	.62409	1.00000	.62292	34, 500, 440-06, 441-06
33	.62401	.56051	1.00000	.76194	6A-33, 633C, 633D, 33, 3333C
E	.78860	.74717	.79680	.62400	3AE, 6AE, 36E

## When Ordering Arbors

Either of the following method is correct—

- a — Show style and size of the mounting shank and the model number of the Jacobs chuck to which the arbor will be fitted.

Example:

A #2 Morse Taper shank arbor for #34 Jacobs Chuck

- b — Show the style and size of the mounting shank plus the actual Jacobs taper desired.

Example:

A #2 Morse Taper shank with a #3 Jacobs taper

- c — Simply use the part number listed in the standard arbor charts shown above (on opposite page)

Example:

One #A0203 Jacobs Chuck Arbor

## Suggested Method for Mounting Drill Chucks

- **ON THREADED SPINDLE PORTABLE TOOLS**—thread chuck on the spindle by hand so that the back of the chuck seats firmly against the mounting surface provided on the portable tool spindle.
- **ON TAPERED SPINDLE PORTABLE TOOLS**—clean both tapers with carbon tetrachloride and wipe with a paper towel to free the tapers of all grease and grit. With the chuck jaws completely retracted into the chuck and using a thin piece of wood to protect the chuck nose, tap the chuck into place on the spindle.
- **ON TAPERED SPINDLE DRILL PRESSES**—follow the same directions as suggested on tapered spindle portable tools.
- **ON TAPERED SHANK ARBORS**—clean both tapers as above. With the jaws retracted into the chuck and with the chuck nose resting on a wooden bench, strike the tang of the arbor lightly to seat it into the chuck. Do NOT assemble on an arbor press as excessive pressure will expand the chuck body and distort the chuck jaw holes.

# Jacobs®

## Rubber-Flex® collet chucks for lathes and other machine tools

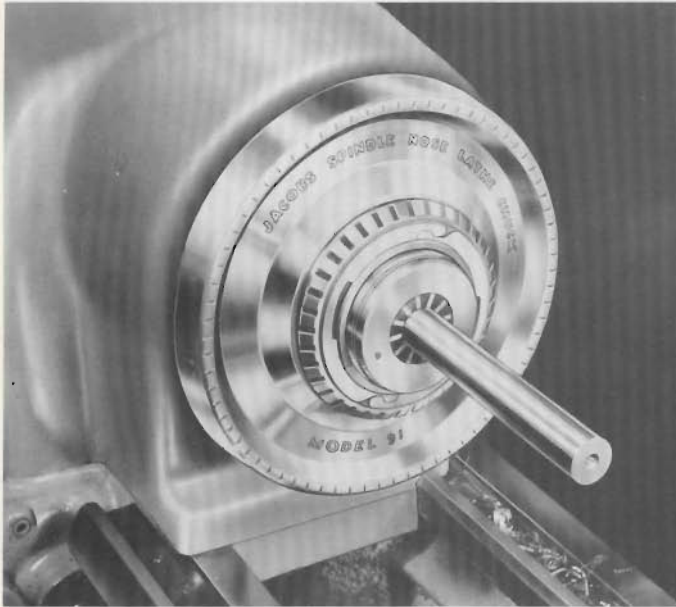

**Spindle Nose Lathe Collet Chuck**

A lathe collet chuck combining the Jacobs Rubber-Flex® Collet, "the collet with a range," and a new principle of impact tightening to give unequalled gripping power, reduced overhang, ultra accuracy, economy, capacity and durability. Only eleven rubber-flex collets required to cover a range from  $\frac{1}{16}$ " to  $1\frac{3}{8}$ ". Ask your distributor for catalog No. 300.



**Model 96 Key Type Collet Chuck**

The model 96 provides another versatile shop tool using Jacobs Rubber-Flex® Collets. Combined with a taper shank arbor or adapter, the Model 96 Chuck can be used on lathe headstocks, jig borers, indexing heads, milling machines, grinders and many others for holding work as well as tool shanks up to  $1\frac{3}{8}$ " in diameter. See catalog No. 300.



**Model 92 Lever Operated**

The new Model 92 Production Collet Chuck offers high speed performance, ease of operation plus the famous accuracy and grip of the Rubber-Flex collets. Ask your Jacobs distributor for Catalogue No. 300.

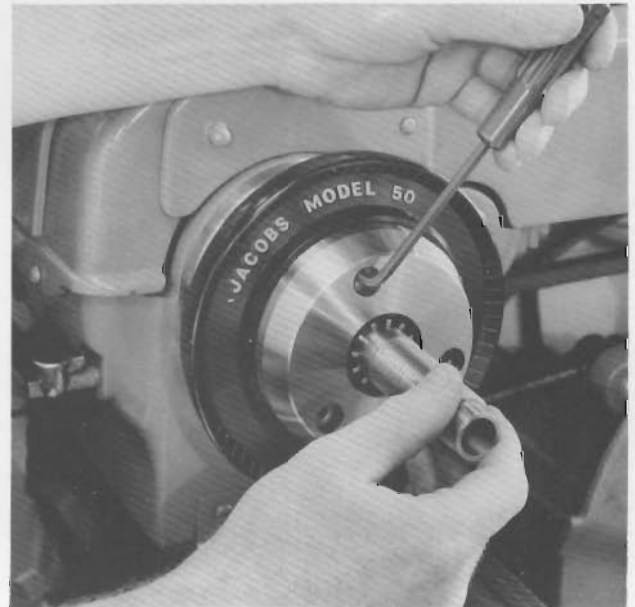

**Model 50 Collet Chuck**

A compact, light weight, low priced collet chuck with hand-wheel operation. Especially designed for Atlas, Clausing, Delta, Logan, Rockwell, Sheldon and South Bend Lathes. Ask for Catalogue No. 300.

# Jacobs®

## service and repair

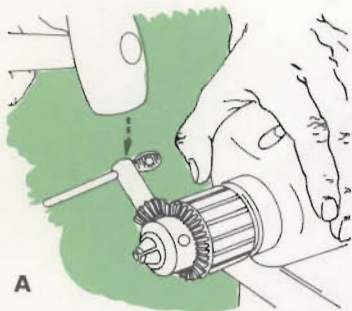

### To remove chucks from portable tool **THREADED SPINDLES** . . .

Chucks with threaded backs can be identified by the letter "B" in the model number. (1B, 32B, etc.) "B" model chucks may be removed from a threaded spindle by inserting a chuck key in a keyhole in the chuck body and striking the key with a sharp hammer blow in a counterclockwise direction. (see A)

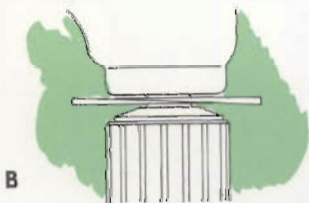

### To remove chucks from portable tool **TAPERED SPINDLES** . . .

If the power tool has a tapered spindle, the chuck may be removed from the spindle by inserting chuck removal wedges between the chuck back and the spindle housing.

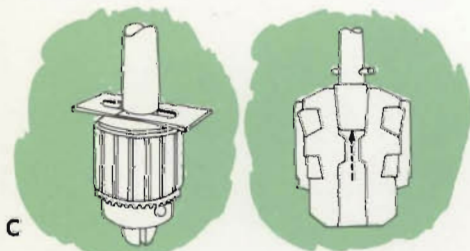

### To remove a chuck from its arbor . . .

Insert wedges between the back of the chuck and the shoulder of the arbor. (see B) In case the mounting taper of the arbor does not provide a shoulder, a cross hole should be drilled through the neck of the arbor, (see C) and a cross pin inserted. Then the wedges can be used between the chuck back and the cross pin. If desired a hole may be drilled through the soft center portion of the chuck body, (see C) and a pin may then be used with an arbor press to force the arbor out of the chuck.

### To disassemble ball bearing super chucks

Extend the jaws to half capacity, press the sleeve off over the jaw end of the body, remove the balls from the race through feeding notch in the nut, leaving the nut and jaws free to be removed. The ball race insert can then be lifted off over the jaw end of the body. (see D)

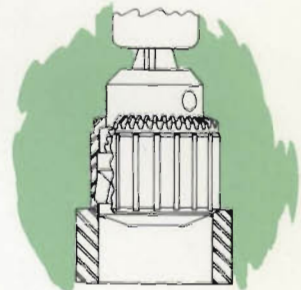

D

### To disassemble plain bearing chucks

Extend the jaws to half capacity, press the sleeve off over the jaw end of the body and take out the nut and jaws (see D)

### To assemble ball bearing super chucks

Slip the ball race over the jaw end of the body, insert the three jaws in the body in proper sequence, advance the jaws to half capacity, apply a good grade of grease to the thread on the nut and place it in position to engage the jaws; then feed balls into ball race through loading notch in the nut, apply good grease to the sleeve and press on the sleeve with an arbor press. (see E)

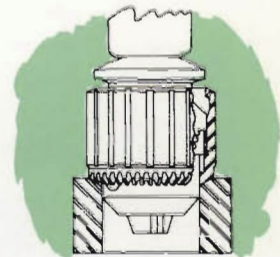

E

### To assemble plain bearing chucks

Follow procedure for ball bearing super chucks, omitting ball race assembly.

## Jacobs Repair Service

JACOBS CHUCKS can be repaired either by purchasing the necessary parts from your distributor, or by having your distributor ship chucks to the factory for reprocessing. Only in this way can chucks be thoroughly overhauled. Bodies will be reground, jaw holes will be refinished, and new parts including the key will be provided. In addition, jaws will be internally ground after assembly in the chuck to insure accuracy. It should be noted, however, that chucks cannot be repaired when bodies are not in good condition, i.e., if the taper hole, key holes, or jaw holes are marred, worn or battered. They should be replaced. See price list for repair charges.

Customers desiring to do their own repair work can do so with a Jacobs Chuck Repair Kit which contains assembly and disassembly rings, wedges and jaw hole reamers. Price available upon request.



The Industrial Supply Distributor has served The Jacobs Manufacturing Company for over 60 years and has contributed immensely to this company's growth and prestige.

He stocks, catalogues and promotes the sale of our chucks in every industrial community throughout the United States and Canada.

He reduces your cost of possession, fortifies you against expensive breakdowns and is a cheerful source of information for thousands of products which he carries for your convenience.

He is one of the most important institutions in the American marketing structure.

We gratefully acknowledge our debt to the Industrial Supply Distributor and salute him for his outstanding service to American Industry.

Jacobs

Jacobs trademark Reg. U.S. Pat. Office

**CHUCKS**

**THE JACOBS MANUFACTURING COMPANY**

West Hartford, Connecticut 06110

Clemson, South Carolina 29631

MFGRS. CODE NO. 7814